

EI. Kraftstoffpumpe / Electric fuel pumps / Pompes à carburant électriques / Bomba de combustible eléctrica / Pompa di alimentazione elettrica

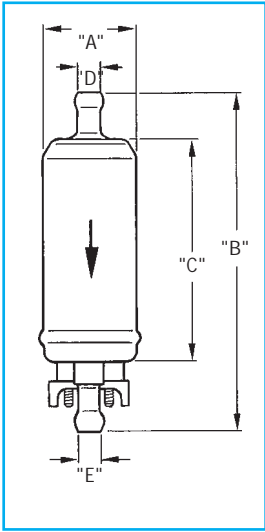

Figure 5

**E1F**  
bis 1,0 bar\*  
up to 14.5 lbf/in2 (psi)\*

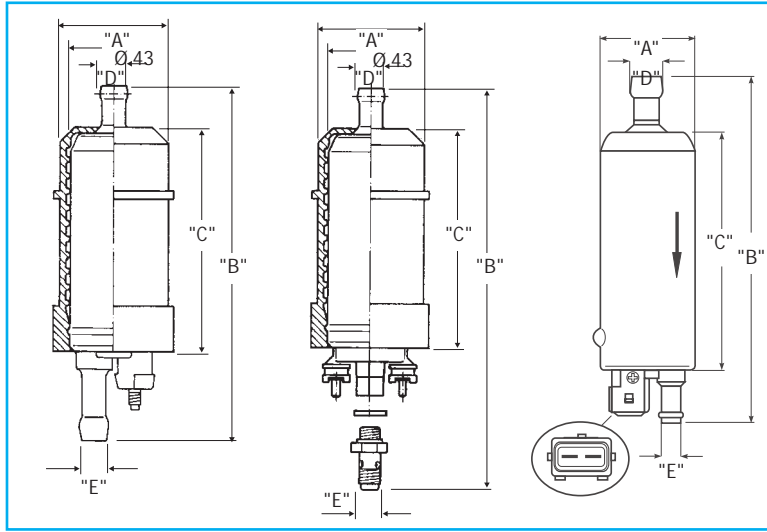

Figure 6 I

6 II

6 III

**E2T**  
2,0-3,5 bar\*  
29.0-50.8 lbf/in2 (psi)\*

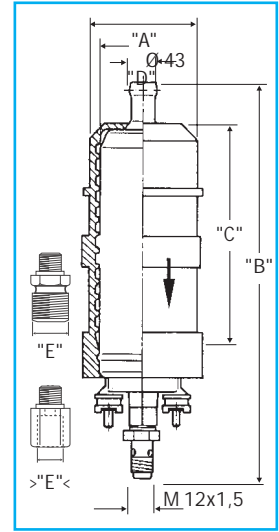

Figure 7

**E3T**  
3,0-6,5 bar\*  
43.5-94.3 lbf/in2 (psi)\*

\* Systemdruck / system pressure

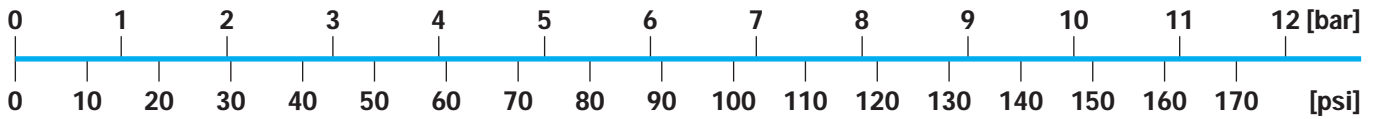

Fig. No.	Part No.	Voltage DC [V]	Stat. press. Q= 0 i/h [bar]	Volume flow [l/h]	Systeme pressure [bar]	Mounting or connection dimensions (mm)					Power consumption max. [≤ A]
						"A"	"B"	"C"	"D"	"E"	
5	7.21 440.10.0	24	0,20 - 0,31	70	0,08	∅ 38	133,5	84,5	∅ 8	∅ 8	1,2
	7.21 440.51.0	12	0,27 - 0,38	95	0,10	∅ 38	133,5	84,5	∅ 8	∅ 8	2,0
	7.21 440.53.0	12	0,44 - 0,57	100	0,15	∅ 38	133,5	84,5	∅ 8	∅ 8	2,05
	7.21 440.63.0	24					134,2				1,35
	7.21 440.05.0	12	0,63 - 0,90	110	0,20	∅ 38	133,5	84,5	∅ 8	∅ 8	2,4
	7.21 440.08.0	12	>1,85	95	1,0	∅ 38	139,5	90,5	∅ 8	∅ 8	4,3
	7.21 440.78.0	12					141,5	91	∅ 12		4,3
	7.21 440.68.0	24					139,5	90,5	∅ 8		3,0
6 I	7.21 287.53.0	12	4,5 - 7,5	100	3,0	∅ 52	160	115	∅ 12	∅ 8	< 6 A at 3,0 bar
6 II	7.21 565.70.0					∅ 52	190	115	∅ 12	M14 x 1,5	
	7.21 565.71.0								∅ 15	M10 x 1,0	
6 III	7.21 538.50.0	12	>2,8	100	1,2	∅ 43	160	110	∅ 12	∅ 8	< 4,5 A at 1,2 bar
7	7.21 659.53.0	12	8,0 - 12,0	110	6,5	∅ 52	178,5	129	∅ 15	M12 x 1,5	< 12 A at 6,5 bar
	∅ 60					∅ 12			>M16 x 1,0<		
						∅ 60	∅ 15		>M16 x 1,0<		